

# ECO20000

Product description: cylindrical 20,000 litre water tank, suitable for commercial or agricultural use

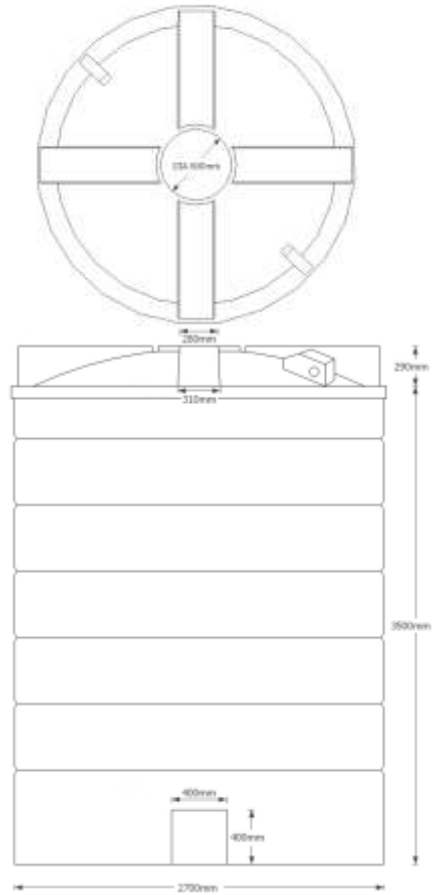

Product Information				
Height	Diameter	Lid	Weight	Outlet
3790mm	2700mm	24" clamped	360kg	None fitted; 1" or 2" supplied loose

Sizes approximate, owing to shrinkage

#### PRODUCT DETAILS:

- Available in either virgin polymer (BLK) or high quality recycled polymer (RE)
- 24"/600mm clamped lid for easy access
- 2" plastic threaded male outlet supplied as standard

#### OPTIONAL EXTRAS:

- 16" lockable lid
- Plastic tank connector (up to 2½")
- Brass tank connector (up to 3")
- Essex flange (up to 2¼")
- Brass isolation valve

#### BENEFITS:

- Suitable for external commercial or agricultural use
- Value for money, high capacity water storage
- Frost proof; will not crack in the cold
- Opaque plastic reduces algae growth in sunlight
- Rotationally moulded for strength and durability
- 10 year warranty against manufacturing defects



Scan to view our full range of water tanks



Etills Ltd  
Unit 1 Whiting Way,  
Melbourn,  
Royston,  
SG8 6NA

Tel: 01763 261781  
Fax: 01763 268409

This specification may be subject to change without notice; please call to confirm details.