

ECO900BLK

Product description: cylindrical 900 litre water tank, suitable for internal or external use

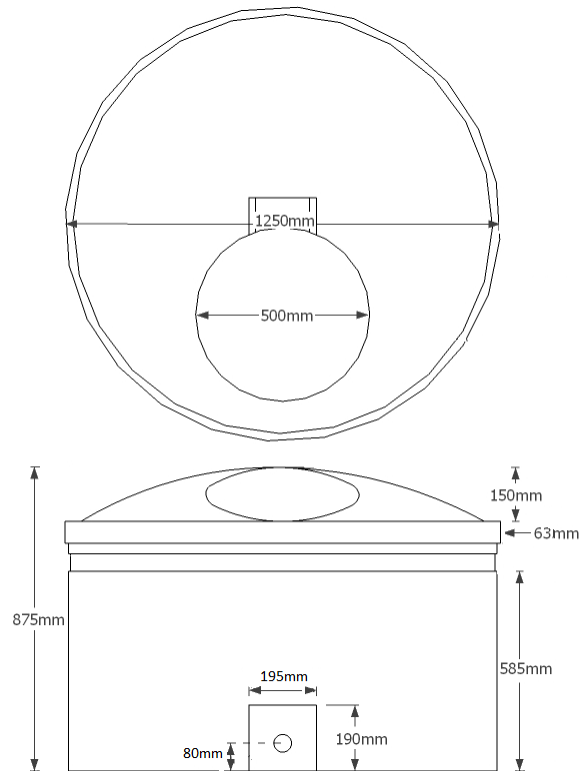

Product Information				
Height	Diameter	Lid	Weight	Outlet
875mm	1250mm	500mm hinged	35kg	1", or 2", or blank

Sizes approximate, owing to shrinkage

PRODUCT DETAILS:

- Made from virgin polymer
- Large, hinged lid for easy access
- 1" BSP brass threaded outlet moulded into tank

OPTIONAL EXTRAS:

- Upgrade to 2" outlet
- Brass tap
- Brass isolation valve with hose connector
- Tank connectors

BENEFITS:

- Suitable for internal and external use
- Ideal for domestic or commercial water storage
- Value for money, high capacity water storage
- Frost proof; will not crack in the cold
- Opaque plastic reduces algae growth in sunlight
- Rotationally moulded for strength and durability
- 1 year warranty against manufacturing defects



Scan to view our full range of water tanks



Etills Ltd
Unit 1 Whiting Way,
Melbourn,
Royston,
SG8 6NA

Tel: 01763 261781
Fax: 01763 268409

This specification may be subject to change without notice;
please call to confirm details.